

PRODUCT DATA and APPLICATION SHEET

Product Name: Large Dolly GPO's 10 Amp

Product Code: GPO1/LD Single GPO Large Dolly
GPO1X/LDX Single GPO with extra switch Large Dolly Vertical
GPO2/LDX Double GPO Large Dolly

Description: 10 Amp Large Dolly GPO's

Features:

- TESLA Large Dolly range has been designed with a soft touch switch mechanism with a profile over 4 times the size of a traditional switch Mech, this allows ease of use for Senior and Assisted living Installs
- The stylish design also suits Recreation Club and Modern Home Architecturally designed installations
- 10Amp 250V
- AS/NZS3100, AS/NZS3112, AS/NZS3133



Ordering Codes

Part Number	Description	Box Qty	Carton Qty
GPO1/LD	Single GPO Large Dolly	10	100
GPO1X/LDX	Single GPO with extra switch Large Dolly Vertical	10	100
GPO2/LDX	Double GPO Large Dolly	10	100



Single Switched Socket Outlet

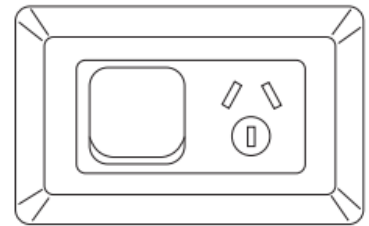

GP01/LD

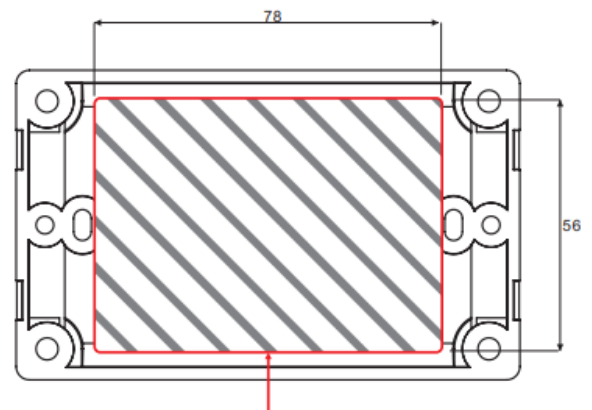
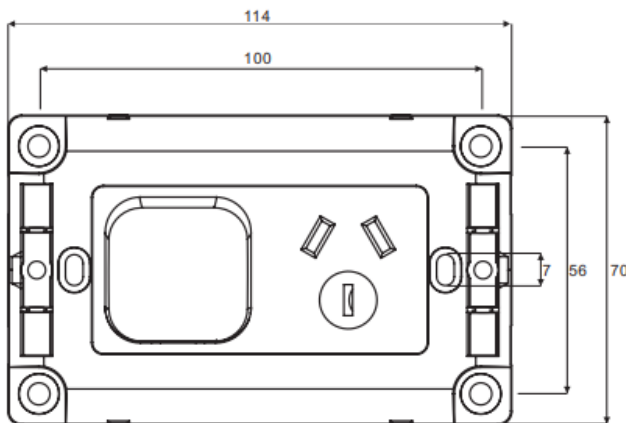

Maximum Clearance Area

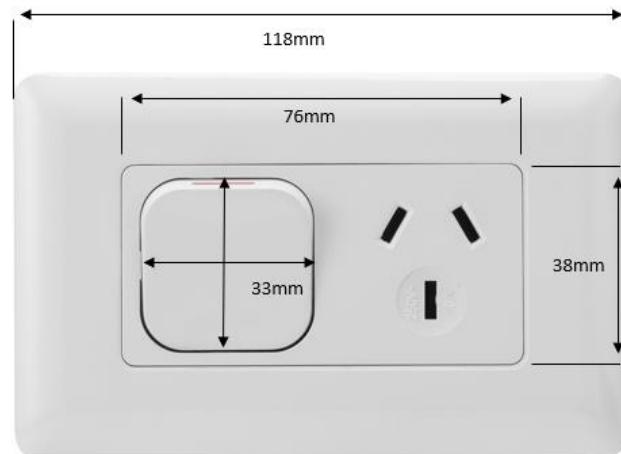

Standard Size - Mounting

Part Number	Description	Length	Width	Depth	Mounting Centre's
GP01/LD	Single GPO Large Dolly	118mm	74mm	26mm	84mm
GP01X/LDX	Single GPO with extra switch Large Dolly Vertical	118mm	118mm	30mm	84mm
GP02/LDX	Double GPO Large Dolly	118mm	118mm	30mm	84mm

Twin Switched Socket Outlet and Large Format Switch Plates

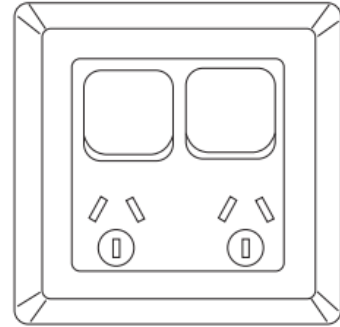

GP02/LDX

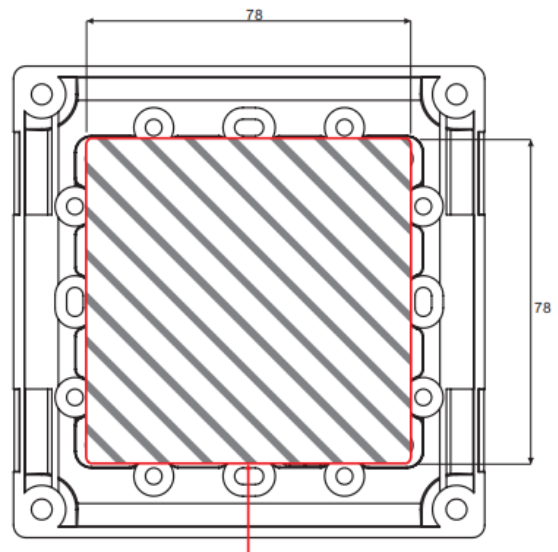
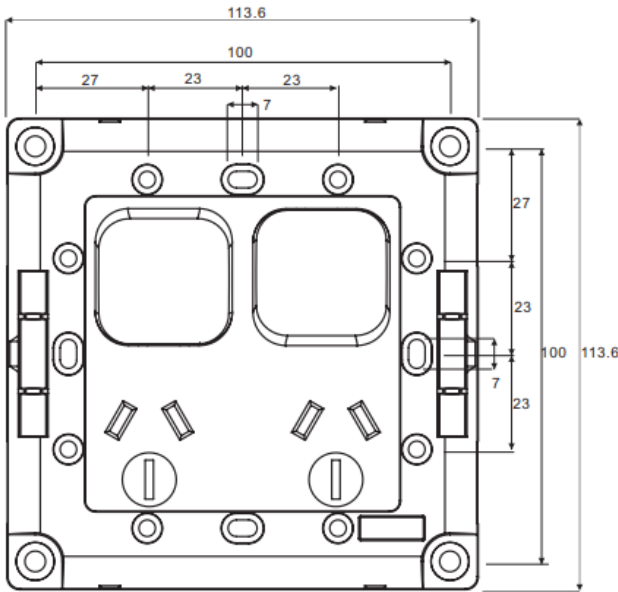

Maximum Clearance Area

